



SMART CITY SOLUTION

2024 Product Catalogue



BRILLIANT GUARD

A construction site at sunset. The sky is a mix of orange, yellow, and blue. In the foreground, there are silhouettes of steel structures and scaffolding. On the right, a yellow tower crane is illuminated by two bright lights at its top. The crane has 'HUNNEBECK' written on its side. The overall scene is industrial and dramatic.

**Smart Connected Products & Solutions
Powered by Brilliant Guard**



SMART. TRANSFORM. CONNECT

The Internet of Things (IoT) plays a crucial role in the development of Smart City infrastructure, enabling seamless collaboration and connectivity among machines in various sectors like transportation, logistics, warehouse management, and facilities maintenance.

This connectivity enhances operational efficiency and reduces costs. Our state-of-the-art smart locks, accessible through mobile apps or smart keys, represent a revolutionary product that combines convenience, security, and easy administration. By effortlessly sharing access control with employees, friends, and family members, supported by our secure cloud-based solutions that ensure real-time data synchronization from anywhere and at any time, access management becomes simple yet secure.

Additionally, our centralized, private, and secure server relays and stores instant notifications about lock status, user activities, and alerts, providing owners with valuable insights into access and location information.

Moreover, our lock solution can integrate with IoT devices such as temperature/humidity sensors and emergency buttons, expanding its functionality and creating a robust and comprehensive Industrial IoT Hub that consolidates machine data.

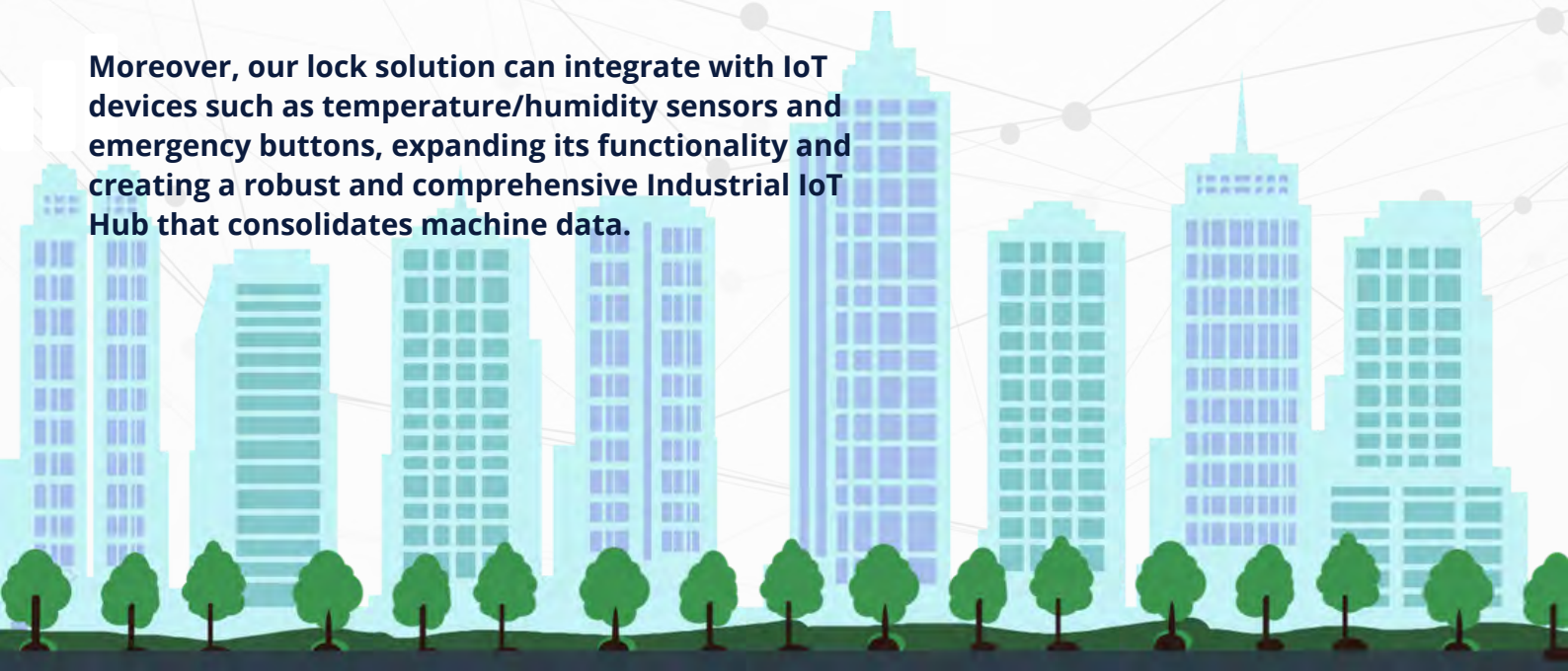

Storage Solution

Our smart cloud-based enterprise solution can be easily deployed in a rural area where smart locks to secure drive-up storage can send out a notification to property management or stakeholders about storage access status. Besides access control, our value-addable solution can be easily integrated into any compatible IOT devices such as smart motion sensors, temperature sensors, flooding sensors, and surveillance cameras for security and protection.

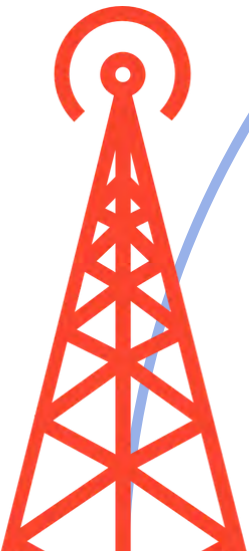

Mobility Solution

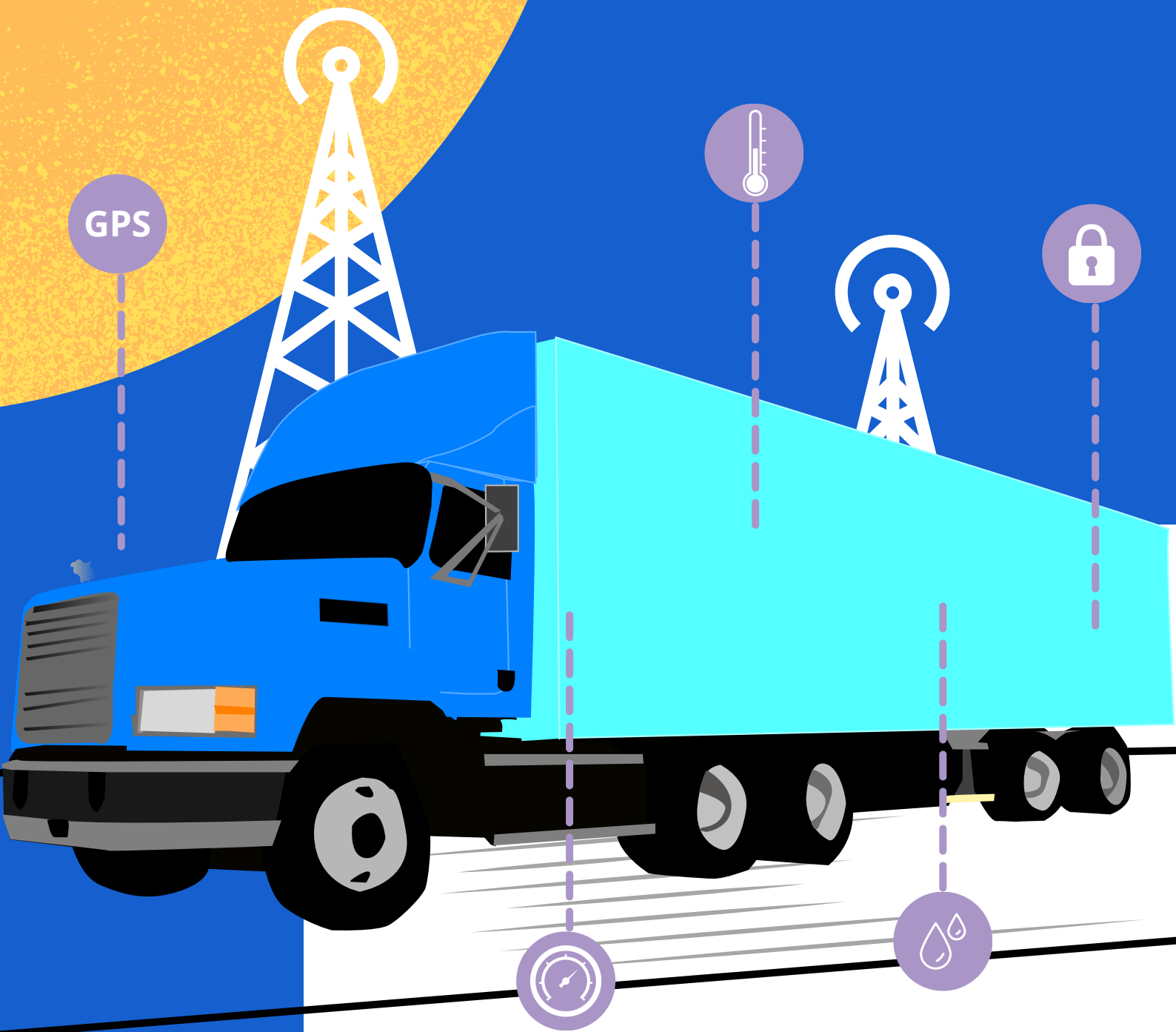

ALWAYS CONNECTED
supported by 4G LTE network

Brilliant Guard WL1289 is a Bluetooth Low Energy (BLE) to Wi-Fi connectivity gateway. This cost-effective, low energy consumption, Wi-Fi enabled with TLS security standard gateway bridging with our BG private server via MQTTS protocol can seamlessly deliver user and device management data from BG locking products anytime, anywhere. This gateway provides hassle-free real-time monitoring solutions in business private networks that can fully protect company and user privacy.

Secured by Brilliant Guard

BG Connect Hub

BG SME connect is an exclusive solution designed and developed for enterprise and small business owners who is valued on property access control and management with real-time notification messages that can be retrieved from a privately managed cloud server. This real-time monitoring, event data storage and management control can provide cost-effective and easy-to-deploy solutions to business offices, warehouses, and commercial buildings to increase access security and provide industrial IOT solutions in no time..

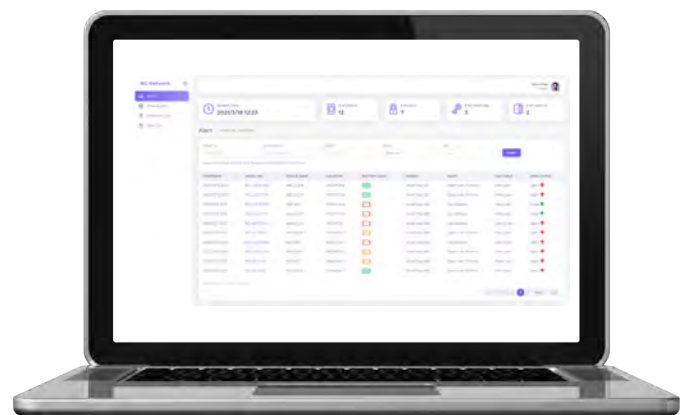
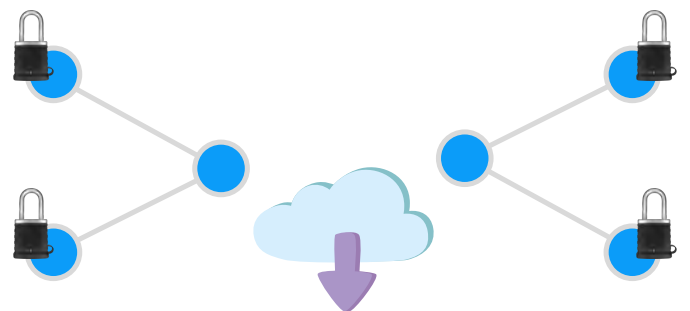

BG Client Portal





The Brilliant Guard Client Portal is a user interface that has been specifically developed to provide customers with access to information about their smart locks. It offers a range of features and functionalities that allow customers to monitor and manage their locks effectively.

One of the primary functions of the Brilliant Guard Client Portal is to provide information about who has accessed the lock. This feature enables customers to track and monitor the lock's usage history, allowing them to know exactly when the lock was opened and by whom. This can be useful for security purposes, as it helps customers keep a record of who has entered their property.

In addition to tracking lock usage, the Brilliant Guard Client Portal also provides real-time lock status updates. Customers can check whether their lock is currently locked or unlocked, providing them with peace of mind and the ability to remotely control the lock if necessary. This feature is particularly convenient for homeowners who want to ensure that their property is secure, even when they are not physically present.

Moreover, the Brilliant Guard Client Portal offers information about the battery level of the smart lock. This feature helps customers keep track of the lock's power status and ensures that they are alerted when the battery is running low. By receiving timely notifications, customers can take the necessary steps to replace or recharge the battery, ensuring that the lock continues to function properly.

Created Date (UTC)	Created Date (Asia/Hong_Kong)	Device name	User Name	Flag	Location	Battery Level	Status
2024-02-08 01:33:16	2024-02-08 09:33:16	BG-PL-1338	tskkyiv	Mobily		100%	Open
2024-01-11 09:19:26	2024-01-11 17:19:26	BG-PL-1338				100%	Closed
2024-01-11 09:19:39	2024-01-11 17:19:39	BG-PL-1338				100%	Open
2024-01-11 08:47:58	2024-01-11 16:47:58	BG-PL-1338				100%	Closed
2024-01-11 08:47:42	2024-01-11 16:47:42	BG-PL-1338				100%	Open
2024-01-11 08:47:21	2024-01-11 16:47:21	BG-PL-1338				100%	Closed
2024-01-11 08:47:09	2024-01-11 16:47:09	BG-PL-1338				100%	Open
2024-01-11 08:46:57	2024-01-11 16:46:57	BG-PL-1338				100%	Closed

Device Name	Image	Device Type	Created Date (UTC)	Created Date (Asia/Hong_Kong)	Battery Level	Status	Lock Status	
000533		E-Lock	2024-03-08 01:37:11	2024-01-11 04:30:00	100%	enabled	open	...
000555		E-Lock	2024-03-08 01:33:16	2024-01-11 04:19:00	100%	enabled	open	...
000627		E-Lock	2024-03-22 02:21:39	2024-01-11 04:56:00	100%	enabled	open	...
Test		E-Lock	2024-01-17 04:06:25	2024-01-11 18:29:00	unknown	enabled	open	...
000566		E-Lock	2024-03-05 01:07:53	2024-01-11 04:11:00	100%	enabled	open	...
000526		E-Lock	2024-03-02 07:48:06	2024-01-11 04:28:00	100%	enabled	open	...

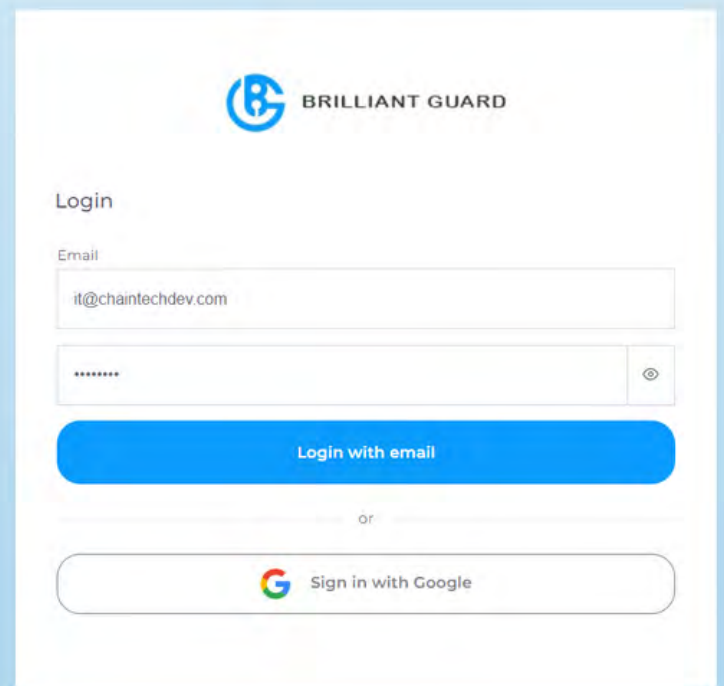

BRILLIANT GUARD

Login

Email

it@chaintechdev.com

Login with email

or

 Sign in with Google



Software Development Kit (SDK)

Are you interested in integrating our solution and implementing our smart lock? We provide a comprehensive suite of software and programming tools specifically designed for developers to create applications for both Android and iOS platforms. Our tools are meticulously crafted to minimize development cycles and accelerate deployment times. Within our SDK package, you'll discover indispensable components, including libraries, documentation, code samples, and guides that seamlessly integrate into your own applications. For Android development, our Android SDK toolkit is indispensable, while for iOS development, our iOS SDK toolkit is a necessity. To learn more about our Brilliant Guard SDK, please visit our website.



2024 Product Portfolio

Smart Connected Locks

Smart Key

Sensors & Gateway



Smart Locks



Dual Secure Access Padlock with tampering alert

BGPL1331

The Brilliant Guard BGPL13331 is a cutting-edge lock that offers users a unique blend of traditional and modern lock opening experiences. In our quest to make it smarter and more eco-friendly, we have incorporated three distinct access methods. Additionally, this advanced model is equipped with anti-theft tampering alert capability if any excessive impact such as hammering or cutting of the lock is detected, buzzing and alert notification will be recorded and being uploaded to the cloud.



Technical specifications

- Material : Zinc Alloy/Boron Alloy Shackle
- Tampering alert volume : 65 dB
- Operating Humidity : From 45 to 75%
- Battery Capacity : Lithium Rechargeable 500mAh
- Dimension & weight : 3.5 x 2.5 x 1.15 inches in 600g
- IP rating : IP65
- Wireless Technology : Bluetooth Low Energy 5.0 compatible
- Wireless Coverage : 30 feet (Line of Sight)
- Display : LED Color Code (Blue, Green, Neon Orange)
- Power Port : Micro-USB connector
- Companion App : Android 6.0 or later, iOS 10.0 or later
- Log Storage : up to 256 event records
- Key Storage : up to 100 keys
- Lock Access : Physical Key, Mobile App and Smart Key (Programmable)

Shackle Protected Padlock

BGPL1333SP

Brilliant Guard BGPL1333SP is developed for Marine Freight Carrier and high theft-risk area that additional shackle protection is needed. Zinc Alloy shackle protector can easily reduce 50% of intruder opportunity to open the shackle. It is fully compliance with Industrial IP standards up to IP66. The lower part of the lock body is protected by heavy-duty plastic to improve accessibility and increase robustness. Sharing lock to the group of friends or colleagues can be just few clicks away. Companion mobile app can be found from Android or iOS app.



Technical specifications

- Material : Zinc Alloy/Boron Alloy Shackle
- Operating Temperature : -10 °C to +60 °C
- Operating Humidity : From 45 to 75%
- Battery Capacity : Lithium Rechargeable 500mAh
- Dimension & weight : 2.5 x 2.5 x 1.2 inches in 480g
- IP rating : IP66
- Wireless Technology : Bluetooth Low Energy 5.0 compatible
- Wireless Coverage : 30 feet (Line of Sight)
- Display : LED Color Code (Blue, Green, Neon Orange)
- Power Port : Micro-USB connector (Type B)
- Companion App : Android 6.0 or later, iOS 10.0 or later
- Log Storage : up to 256 event records
- Key Storage : up to 100 keys
- Lock Access : Mobile APP and Smart Key (Programmable)

Smart High Precious Padlock

BGPL1338

Brilliant Guard BGPL1338 is designed to transform conventional keyed padlocks into Keyless, the smartphone manages and patented smart key features but retains industrial heavy-duty protection and an easy-to-use design. From design to manufacturing is all under one experienced engineering team. Features such as easy user management and event collection can now allow an owner to administrate their property at their fingertips.

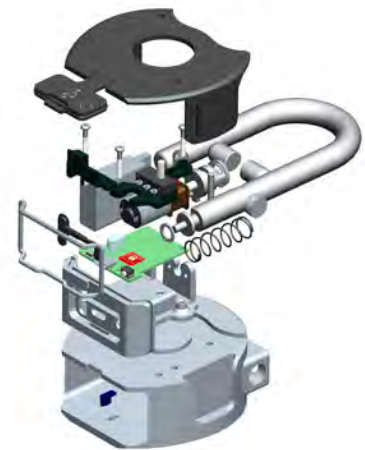

Technical specifications

- Material : Zinc Alloy/Boron Alloy Shackle
- Operating Temperature : -10 °C to +60 °C
- Operating Humidity : From 45 to 75%
- Battery Capacity : Lithium Rechargeable 500mAh
- Dimension & weight : 2.5 x 2.5 x 1.2 inches in 480g
- IP rating : IP65
- Wireless Technology : Bluetooth Low Energy 5.0 compatible
- Wireless Coverage : 30 feet (Line of Sight)
- Display : LED Color Code (Blue, Green, Neon Orange)
- Power Port : Micro-USB connector (Type B)
- Companion App : Android 6.0 or later, iOS 10.0 or later
- Log Storage : up to 256 event records
- Key Storage : up to 100 keys
- Lock Access : Mobile APP and Smart Key (Programmable)

Smart High Precious Padlock

BGPL1334WP

Brilliant Guard BGPL1334WP is developed for indoor/outdoor warehouses, goods container freight, and utility buildings. It is fully compliance with Industrial IP standards up to IP66. The lower part of the lock body is protected by heavy-duty plastic to improve accessibility and increase robustness. Sharing a lock with a group of friends or colleagues can be just a few clicks away. Companion mobile app can be found on Android or iOS app



Technical specifications

- Material : Zinc Alloy/Boron Alloy Shackle
- Operating Temperature : -10 °C to +60 °C
- Operating Humidity : From 45 to 75%
- Battery Capacity : Lithium Rechargeable 500mAh
- Dimension & weight : 2.5 x 2.5 x 1.2 inches in 480g
- IP rating : IP65
- Wireless Technology : Bluetooth Low Energy 5.0 compatible
- Wireless Coverage : 30 feet (Line of Sight)
- Display : LED Color Code (Blue, Green, Neon Orange)
- Power Port : Micro-USB connector (Type B)
- Companion App : Android 6.0 or later, iOS 10.0 or later
- Log Storage : up to 256 event records
- Key Storage : up to 100 keys
- Lock Access : Mobile APP and Smart Key (Programmable)

Mini Keyless Lockbox

BGKL1289

Brilliant Guard BGKL1289 is our compact version of a keyless lockbox that is exclusively designed to good fit for Airbnb and the real estate market designed to latch directly over the door knob or handle, making it ideal for those with frequent houseguests or rental tenants.

Constructed of rust-resistant steel, this lock can be used for both indoor and outdoor use, also the storage is large enough to hold up to five standard-size keys, and setting combination is easy to set through BG connect mobile app, which can identify all PIN users in access logs.



Technical specifications

- Material : Zinc Alloy/Boron Alloy Shackle
- Operating Temperature : -10°C to +60°C
- Operating Humidity : From 45 to 75%
- Battery Capacity : Lithium Rechargeable 2000mAh
- Dimension & weight : 2.0 x 3.75 x 3.25 inches in 600g
- IP rating : IP65
- Wireless Technology : Bluetooth Low Energy 5.0 compatible
- Wireless Coverage : 30 feet (Line of Sight)
- Display : LED Color Code (Blue, Green, Neon Orange)
- Power Port : Micro-USB connector (Type B)
- Companion App : Android 6.0 or later, iOS 10.0 or later
- Log Storage : up to 1000 event records
- Key Storage : up to 100 keys
- Lock Access : Pin Code, Mobile App and Smart Key (Programmable)

Smart Key

With Smart Key, Perfect access control allows one key for all locks.

01. The smart key is capable of opening locks manufactured by Brilliant Guard*, all the access is integrated into one key.
02. The critical issue of the electricity lock is battery outage, Smart Key acts as an electricity booster to open the lock even battery drains.
03. The smart key can easily be set up and managed by an app (Android and iOS). With just a few clicks, you can specify any lock that you want to add.
04. The user data are transmitted and stored at the encrypted cloud server. If you lose your phone, your data will be protected and retrieved from our secured cloud server.
05. Environmental Friendly - No more spare keys and replacement locks. It's eco-friendly and cost-effective.
06. Each rechargeable key supports up to 100 locks open, so no more carrying heavy metal keys (ex Avg. 11g x 100 ~ 1100g), all you need now is one smart key (~ 35g).

*Smart key works for all BG locking products

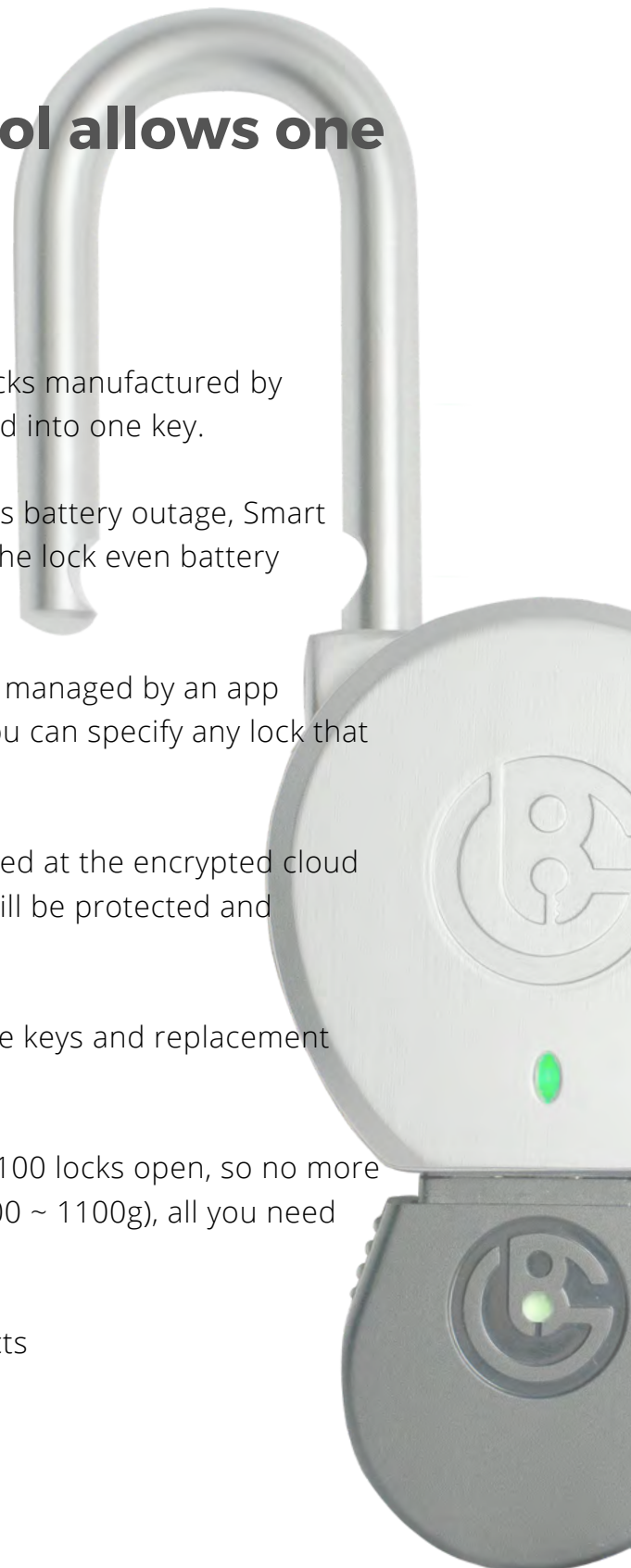

Smart Key - All you need is one key

BGMK6338

Brilliant Guard BGMK6338 is designed to provide an alternative way to access your private locking system and manage remote properties. With a portable lightweight but built with durable material and a compact design. Smart -key built with state-of-art wireless hardware and industrial-approved secured digital key algorithm. Our companion smartphone App can be used to manage and collect all selectively connected locking system activities. Whether you are a small business owner or factory manager, a smart key is a simple way to start your lock management.



Technical specifications

- Material : Plastics Body & Zinc Alloy Cover
- Operating Temperature : -10 °C to +60 °C
- Operating Humidity : From 45 to 75%
- Battery Capacity : Lithium Rechargeable 250mAh
- Dimension & weight : 1.8 x 2.6 x 0.5 in 34g
- Wireless Technology : Bluetooth Low Energy 5.0 compatible
- Wireless Coverage : 30 feet (Line of Sight)
- Display : LED Color Code (Blue, Green, Neon Orange)
- Power Port : Micro-USB connector (Type B)
- Companion App : Android 6.0 or later, iOS 10.0 or later
- Log Storage : up to 256 event records
- Key Storage : up to 100 locks
- Key Access : Any Brilliant Guard lock

Sensors & Gateway



With the continued influx of connected devices, organizations are looking for ways to gain better visibility of connected devices, control their access to the network, and apply security to IoT devices that lack embedded security features. Ongoing monitoring of IoT devices is needed so that abnormal behavior can be detected and remediated quickly and efficiently.

Secure and Monitor Connected Devices with BG Connect Hub

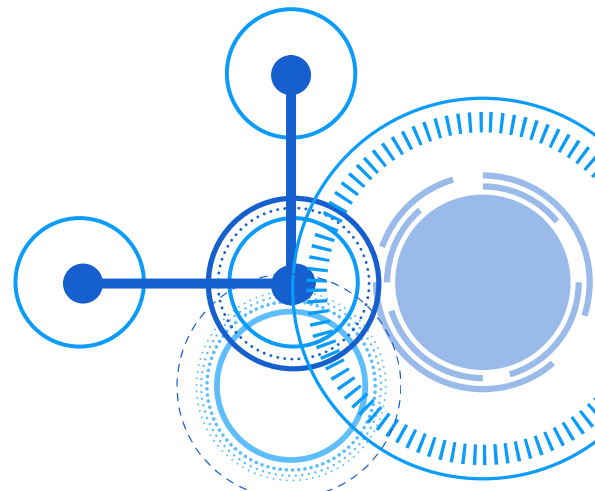

BLE-WIFI Gateway

BGWL1289

Brilliant Guard WL1289 is a Bluetooth Low Energy (BLE) to Wi-Fi connectivity gateway. This robust, Wi-Fi enabled with TLS security standard gateway bridging with our BG private server via MQTTS protocol can seamlessly deliver user and device management data from BG locks anytime, anywhere. This gateway provides hassle-free real-time monitoring in our workspace solution in a private network.



Technical specifications

- Material : Plastic ABS
- Color : White
- Weight : 138g
- Size : Lithium Rechargeable 2000mAh
- Scanning Range : 4.7 x 4.7 x 0.9 inches
- Protocol : MQTT (TCP/SSL)
- Charging : POE / DC Power / Micro USB

BLE-Temperature Sensor **BGNS1112**

Provides a simple solution for monitoring temperature and relative humidity

APPLICATION:

- Cold room
- Refrigerator
- Medical laboratory
- Server equipment



NB-IOT Water Leakage Sensor **BGSEN20310-0000**

Provides a simple and efficient solution for monitoring flooding

APPLICATION:

- Water pipes room
- Data center subfloors
- HVAC equipment
- Smart toilet



Air Quality Monitor Sensor **BGSEN10701**

General Environment air quality Sensor provides a simple and cost-effective

APPLICATION: Air Quality Monitoring

- Office
- Shop
- Mall
- School



Quality Build



Our in-house lock factory in China is dedicated to the production of exceptional locks renowned for their durability and superior quality. We employ a team of skilled craftsmen and utilize advanced manufacturing processes to ensure that each lock meets stringent standards..

At our facility, we prioritize the use of high-quality materials sourced from trusted suppliers. We understand the importance of security, and therefore, we meticulously select robust and reliable components for our locks. This ensures that our products offer long-lasting performance and provide a high level of protection.

Customization



In addition to our standard lock offerings, we take pride in providing customization options to meet the unique requirements and preferences of our customers. We understand that different applications may call for specific features or designs, and we are committed to delivering tailored solutions.

Our team works closely with customers to understand their specific needs and specifications. Whether it's a particular size, shape, finish, or additional security features, we collaborate to create customized lock solutions that align with their requirements. We leverage our expertise and manufacturing capabilities to bring these custom designs to life.

Smart Site Safety System

Our locks are specifically designed to be an integral part of the 4S Smart Site Safety System, which aims to enhance site safety performance by swiftly identifying potential hazards or incidents and implementing immediate mitigation measures. Furthermore, through the analysis of data collected by the system, it becomes possible to uncover the root causes of safety issues, facilitating the formulation of effective enhancement measures.



- HK Address : Unit 1307, 15-59 Au Pui Wan Street, Fo Tan, Shatin, Hong Kong
- HK Phone : (852) 2690 4219
- US Address : 2121 S. China PL A, Chicago, IL, 60616, United States
- US Phone : (630) 229 4601
- Mail : info@brilliantguard.com
- Web : www.brilliantguard.com



BRILLIANT GUARD